

PureFeed® AP-300



Designed specifically for pharmaceutical processes the PureFeed® AP-300 feeder includes the following customer driven features; quick and easy disassembly, a dual arm external agitation system for maximizing material handling versatility, and an FDA compliant EPDM feed hopper that is "disposable" and "recyclable". That means simpler, shorter cleaning cycles and virtually no chance of cross contamination when moving from one material to another.

PureFeed® AP-300 is available in volumetric and gravimetric configurations for pharmaceutical, nutraceutical and even cosmetic applications involving feed rates from 0.5 Kg / hour to approximately 150 Kg / hour. Jet milling, hot melt extrusion, continuous blending, medical-grade plastics compounding, packaging, coating, continuous granulation, and ingredient weighing are examples of the primary applications that fit the PureFeed® AP-300 well.

MATERIAL CONSTRUCTION:

Contact materials-

- White FDA EPDM, 316 and 316 L stainless steel, FDA PTFE (Rulon 641), FDA PET-P (Ertalyle), FDA Black BUNA or White Silicone*.

*NOTE: This is a complete list. Some materials may not be present in certain configurations.

Non-contact materials-

- 304 and 316 stainless steel, White FDA EPDM, FDA PTFE.

SURFACE FINISHES:

- Standard 32 microinch (0.8 micro-meter) Ra finish for contact and non-contact areas. Smoother finishes are optionally available.

FEED RATES:

- Helix diameters from 0.25" (6 mm) to 1.25" (32 mm) provide feed rates from 0.5 kg/hr. to 150 kg/hr. (theoretical).

FEED SCREWS:

- 316 stainless steel.
- 0.25" (6 mm), 0.50" (13 mm), 0.75" (19 mm), and 1.25" (32 mm) machined screws.
- 0.50" (13 mm), 0.75" (19 mm), and 1.25" (32 mm) open flight helixes.
- Full and half pitch configurations are available in select sizes.

DISPOSABLE FEED HOPPER:

- Flexible FDA compliant EPDM feed hopper that is disposable and recyclable.
- Available in 19 mm and 32 mm trough sizes to minimize residual material.

HOPPER EXTENSIONS:

- 4 L, 12 L, and 36 L capacities.
- Dust tight 360 degree sanitary quick release clamp mounting (bolted clamps are optional).

MOTOR SPECIFICATIONS:

- Agitation Drive
 - NEMA 23 frame stepper gear motor with integral motion control.
 - 48 VDC, 2A
 - Gear ratio 22:1 (agitation drive only)
- Helix Drive
 - NEMA 34 frame stepper motor with integral motion control.
 - 48 VDC, 4A
- Configurations for hazardous electrical classifications available.

WEIGH MODULE SPECIFICATIONS:

- Platform with single IP-65 rated stainless steel shear beam strain gauge load cell.
- Weigh modules available in 66 lbs. (30 kg), 132 lbs. (60 kg), and 220 lbs. (100 kg) capacities.

PERFORMANCE:

- Volumetric accuracies of ± 1.5 to 2.5% of feed rate setpoint typical at 2 sigma.
- Gravimetric accuracies of ± 0.25 to 1% of feed rate setpoint typical at 2 sigma.

NOTE: Laboratory testing to determine specific material feeding accuracy is recommended and available from Schenck AccuRate.

PureFeed® AP-300 Auger Feeder

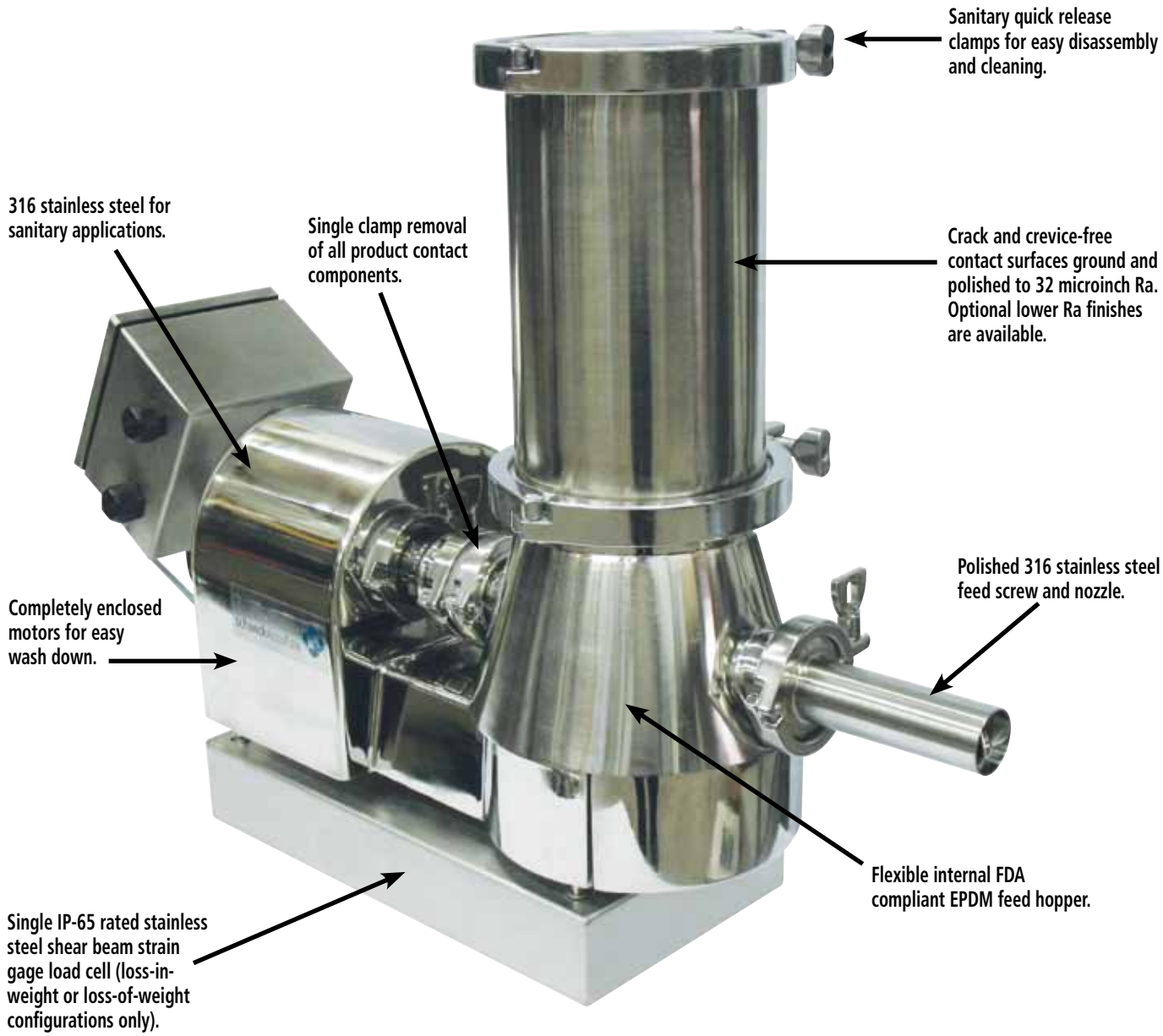

Disposable, recyclable, and flexible FDA compliant EPDM feed hopper provides simpler, shorter cleaning cycles and virtually no possibility of cross contamination when moving from one material to another.

Steps for easy disassembly



1
A single sanitary quick release clamp removes all product contact components.



2
Cover is removed by disconnecting clamp.



3
After releasing clamp the extension hopper is easily removed.



4
Helix is removed for cleaning and product changeover.



5
Nozzle slides out, allowing disposable hopper to be removed.



6
Disposable and recyclable flexible FDA compliant EPDM feed hopper is quickly and easily removed.



The PureFeed® AP-300 Feeder uses minimal components making disassembly quick and easy for routine maintenance and product changeovers.

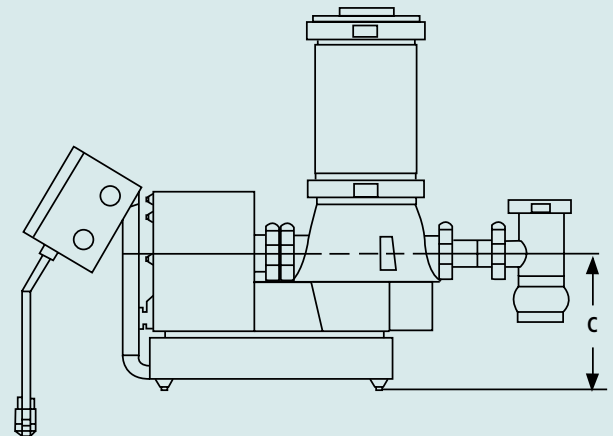
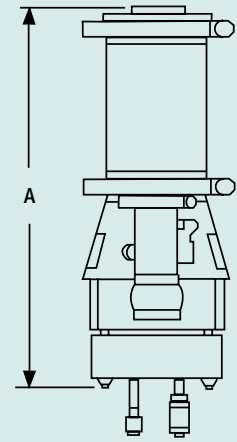
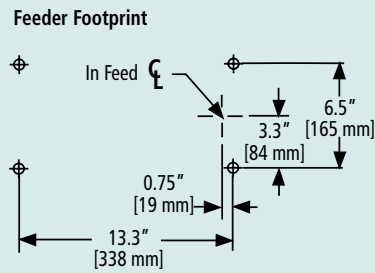
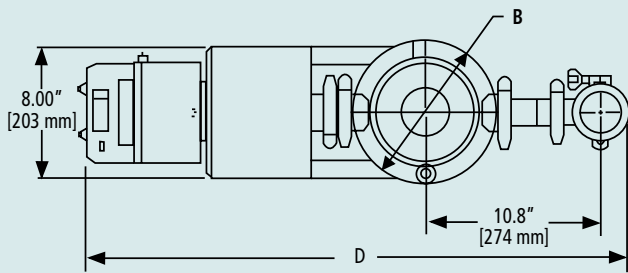

EQUIPMENT CONFIGURATION	WEIGHT	HOPPER CAPACITY
Feeder (Dead Load)	48 lbs. (22 kg)	1.3 L
Extension Hoppers		
4 L	6.5 lbs. (2.9 kg) (shown)	4 L
12 L	9.5 lbs. (4.3 kg)	12 L
36 L	17.5 lbs. (8.0 kg)	36 L
Covers		
4 L	2.7 lbs. (1.2 kg) [SS], 0.8 lbs. (0.36 kg) [PTFE]	
12 L	4.0 lbs. (1.8 kg) [auto or manual]	
36 L	9.0 lbs. (4.1 kg) [auto or manual]	
Totals		
Feeder + 4 L + Cover	57.2 lbs. (26 kg) [SS], 55.3 lbs. (25.1 kg) [PTFE]	5.3 L
Feeder + 12 L + Cover	61.5 lbs. (27.9 kg)	13.3 L
Feeder + 36 L + Cover	74.5 lbs. (33.8 kg)	37.3 L
Scale + Feeder + 4 L + Cover	73.9 lbs. (33.6 kg) [SS], 72 lbs. (32.7 kg) [PTFE]	5.3 L
Scale + Feeder + 12 L + Cover	78.2 lbs. (36.5 kg)	13.3 L
Scale + Feeder + 36 L + Cover	91.2 lbs. (41.4 kg)	37.3 L

NOTES:

- Standard infeed to discharge is 275 mm [10.83"]. Extensions available in 25.4 mm [1.00"] increments to a maximum infeed to discharge of 529 mm [20.83"].
- Extension hoppers are available in 4 L, 12 L, and 36 L sizes. Cover is available in manual refill, auto refill (12 L & 36 L only), or with no cover.
- Electrical service requirements:
240 VAC, 1 phase, 50/60 Hz, 3 amps
120 VAC, 1 phase, 50/60 Hz, 6 amps
- Overall height of feeder and discharge centerline could increase by 6.4 mm [.25"] for volumetric systems when the leveling feet are extended and by 12.7 mm [.50"] when the scale & feeder leveling feet are fully extended in a gravimetric system.
- In gravimetric systems the feeder is removable from the scale for cleaning.
- Quick disconnect power and control cables allow for easy disassembly.

PUREFEED® AP-300				
Extension Hopper Capacity	Dimension "A"	Dimension "B"	Dimension "C"	Dimension "D"
4 L Volumetric	20.6" (523 mm)	8.7" (221 mm)	5.4" (137 mm)	26.3" (668 mm)
4 L Gravimetric	23.9" (607 mm)	8.7" (221 mm)	8.7" (221 mm)	32.9" (836 mm)
12 L Volumetric	25.5" (648 mm)	12.3" (313 mm) conical shape	5.4" (137 mm)	26.3" (668 mm)
12 L Gravimetric	28.8" (732 mm)	12.3" (313 mm) conical shape	8.7" (221 mm)	32.9" (836 mm)
36 L Volumetric	31.0" (787 mm)	19.3" (490 mm) conical shape	5.4" (137 mm)	26.3" (668 mm)
36 L Gravimetric	34.3" (871 mm)	19.3" (490 mm) conical shape	8.7" (221 mm)	32.9" (836 mm)

Dimensions based on layout with downturn nozzle.

Schenck AccuRate
746 E. Milwaukee Street
Whitewater, WI 53190
800-558-0184 or Fax: 262-473-4384
E-mail: mktg@accuratefeeders.com
Web site: www.accuratefeeders.com

